

# ARNO<sup>®</sup>

## WERKZEUGE

# ARNO FAST CHANGE FOR TSUGAMI

# NEW

B0325-III

B0326-III

SS327-III-5AX

S205-II

S206-II

## ZUSAMMENARBEIT!



# TSUGAMI

AMERICA

Speed · Accuracy · Rigidity



# ARNO tool holders for sliding head lathes With internal cooling



KAM = coolant adapter options  
 V = coolant supply is ensured via UN in this range  
 SGS = locking threaded pin - for two separate pressure chambers (high pressure)  
 Similar to illustration

For Model:  
 S205-II  
 S206-II  
 Front Station

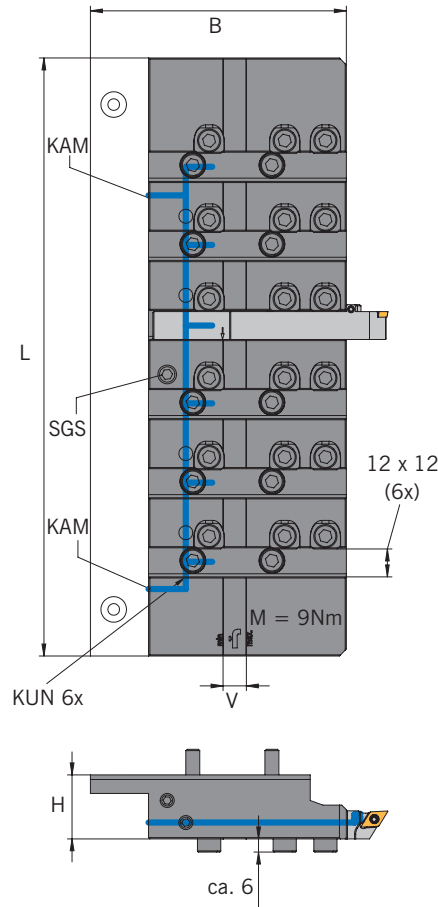

For tool holder selection, refer to the following catalog:  
 Download it at  
<https://arnousa.com/catalogs>



## Holders

Designation	EDP-No.	L	B	H	12 x 12	V	KAM
AWL-TSU-3281-T2030-0100-1K <sup>N</sup>	125786	257	110	27,5	6x	10	G1/8" (2x)

**!** Note: Please use the fixed stop AHA-TSU-1212-S-12-33-AFC

Matching fixed stops for IK transfer are included in the Swiss type machining catalogue and its product expansion.

**ARNO<sup>®</sup> SpecialDesign**

Note: Special dimensions and modifications are available on request.

## Spare Parts

Holder	Clamping wedge	Dummy plug	Screw plug	Lockingthreadedpin	Torque wrench T-handle	Hexagonal blade
AWL-TSU-3281-T2030-0100-1K	AWL-SK111345	GN749-G178-A	AS 0075 <sup>1)</sup>	AWL-SGSM0816	T53	T53SW5

1) Once the screw plug is tightened it can not be removed anymore.

## ARNO tool holders for sliding head lathes With internal cooling

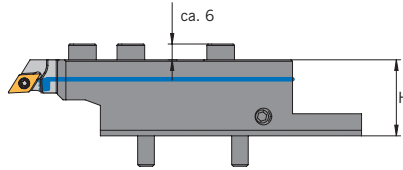

For Model:  
S205-II  
S206-II

Rear Lower Station

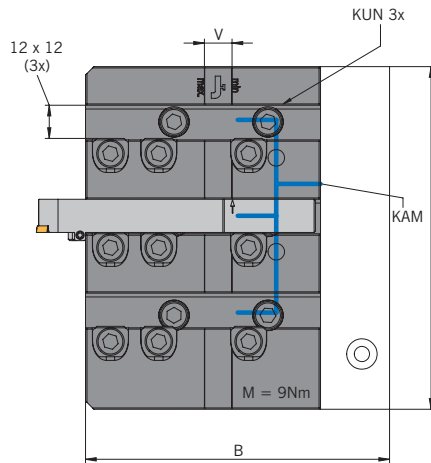

KAM = coolant adapter options  
V = coolant supply is ensured via UN in this range  
SGS = locking threaded pin - for two separate pressure chambers (high pressure)  
Similar to illustration

For tool holder selection, refer to the following catalog:  
Download it at  
<https://arnousa.com/catalogs>



### Holders

Designation	EDP-No.	L	B	H	12 x 12	V	KAM
AWL-TSU-3281-T2030-0200-1K	125788	124	110	27,5	3x	10	G1/8" (1x)

Note: Please use the fixed stop AHA-TSU-1212-S-12-33-AFC

Matching fixed stops for IK transfer are included in the Swiss type machining catalogue and its product expansion.

### ARNO® SpecialDesign

Note: Special dimensions and modifications are available on request.

### Spare Parts

Holder	Clamping wedge	Dummy plug	Screw plug	Locking threaded pin	Torque wrench T-handle	Hexagonal blade
AWL-TSU-3281-T2030-0200-1K	AWL-SK111345	GN749-G178-A	AS 0075 <sup>1)</sup>	AWL-SGSM0816	T53	T53SW5

1) Once the screw plug is tightened it can not be removed anymore.

## ARNO tool holders for sliding head lathes With internal cooling



KAM = coolant adapter options

V = coolant supply is ensured via UN in this range

Similar to illustration

For Models:  
B0325-III  
B0326-III  
SS327-III-5AX

Front Station

Chucker Mode  
Bushing Mode

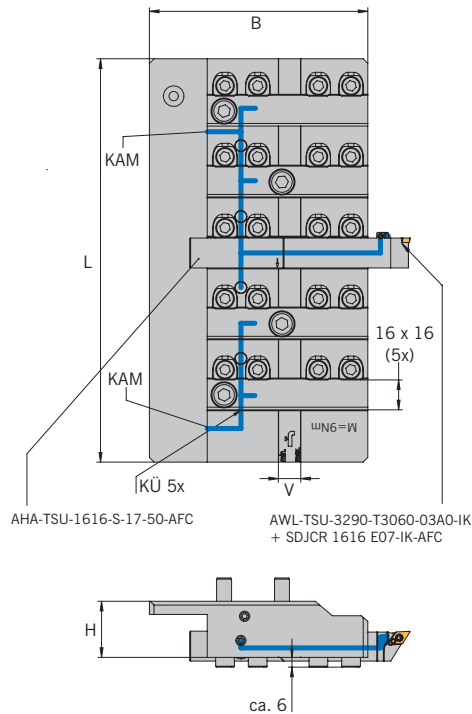

For tool holder selection, refer to the following catalog:  
Download it at  
<https://arnousa.com/catalogs>



### Holders

Designation	EDP-No.	L	B	H	16 x 16	V	KAM
AWL-TSU-3290-T3060-03A0-1K <b>N</b>	122671	216	117	30	5x	12	Rp1/8"(2x)

**!** Note: Please use the fixed stop AHA-TSU-1616-S-17-50-AFC.

Matching fixed stops for IK transfer are included in the Swiss type machining catalogue and its product expansion.

### ARNO® SpecialDesign

Note: Special dimensions and modifications are available on request.

### Spare Parts

Holder	Clamping wedge	Dummy plug	Screw plug	Torque wrench T-handle	Hexagonal blade
AWL-TSU-3290-T3060-03A0-1K	AWL-SK111345	GN749-G178-A	AS 0075 <sup>1)</sup>	T53	T53SW5

1) Once the screw plug is tightened it can not be removed anymore.

*Una volta serrata la vite non sarà più possibile rimuoverla*

*Une fois la vis d'obturation serrée, elle ne peut plus être démontée.*



# ARNO tool holders for sliding head lathes With internal cooling



KAM = coolant adapter options

V = coolant supply is ensured via UN in this range

Similar to illustration

For tool holder selection, refer to the following catalog:  
Download it at  
<https://arnousa.com/catalogs>

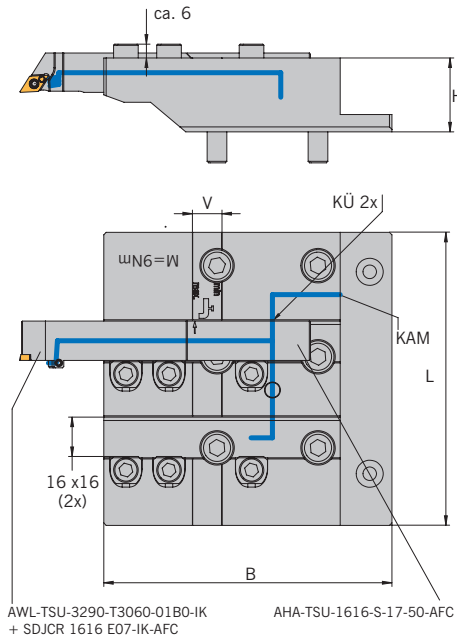

AWL-TSU-3290-T3060-01B0-1K + SDJCR 1616 E07-1K-AFC

AHA-TSU-1616-S-17-50-AFC

For Models:  
B0325-III  
B0326-III

Rear Lower Station

Chuck Mode  
Bushing Mode

Not Compatible with SS327-III-5AX



## Holders

Designation	EDP-No.	L	B	H	16 x 16	V	KAM
AWL-TSU-3290-T3060-01B0-1K	122670	119	117	30	2x	12	Rp1/8"(1x)

## Spare Parts

Holder	Clamping wedge	Dummy plug	Screw plug	Torque wrench T-handle	Hexagonal blade
AWL-TSU-3290-T3060-01B0-1K	AWL-SK111345	GN749-G178-A	AS 0075 <sup>1)</sup>	T53	T53SW5

1) Once the screw plug is tightened it can not be removed anymore.

### AHA-TSU-AFC

Caution: This fixed stop is only designed for ARNO tool holders (AWL-....) with side transfer.

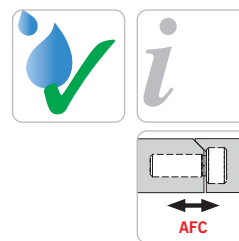

Similar to illustration

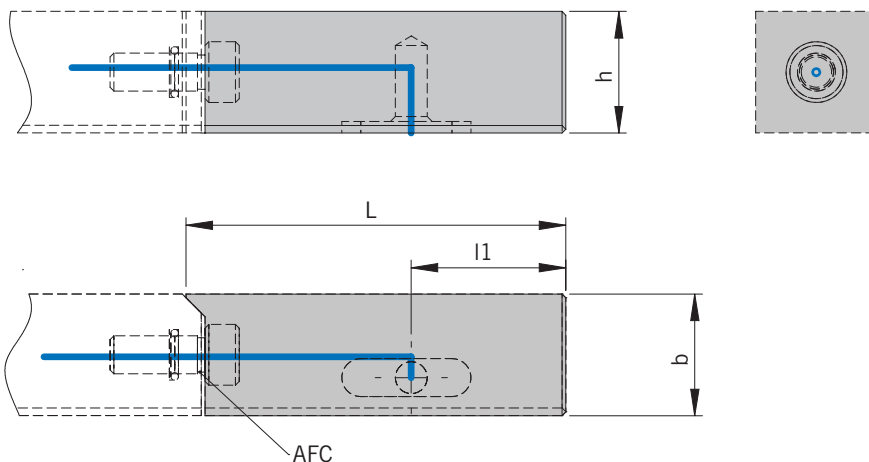

#### Holders

Designation	EDP-No.	L	L <sub>1</sub>	h	b
AHA-TSU-1212-S-12-33-AFC	125789	33	12	12	12
AHA-TSU-1616-S-17-50-AFC	122665	50	17	16	16

#### Spare Parts / Ricambi / Pièces de rechange

Holder	AFC Pin	Key
AHA-TSU-....-AFC	458101	S-AFC-HSK25

## Benefits of the ARNO FAST CHANGE system

### IT'S FAST...

Swap out your spent tool with a fresh one from the bench in about 30 seconds. The self-releasing wedge system will have your tool holder free in just half a turn of the allen wrench. Forget about taking extra time to pry out those old, outdated wedge clamps... ARNO doesn't roll like that.

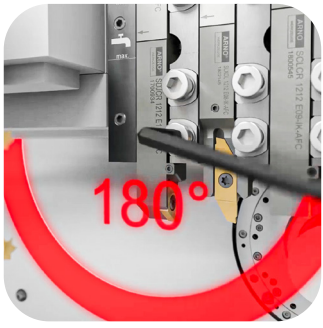

### IT'S ACCURATE...

When the cutting head is replaced, you won't have to guess where the tool point is. The split-shank tools are designed to repeat to within  $\pm .0008''$ . This system is engineered to optimize spindle up-time to keep you making finished parts. No touching off, just off and running.



### IT'S SECURE...

The cutting head is locked into the gang plate with two powerful clamps. It's a rigid connection that maximizes cutting stability, ensuring long tool life and superior surface finishes. There are systems out there with "quick" connections below the gang plate, but we believe that's a compromise to the tool's integrity.

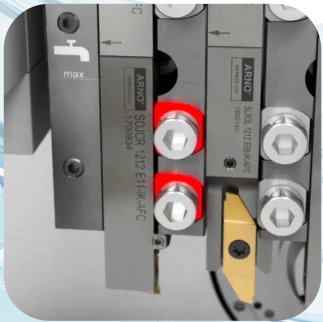

### IT'S COOL...

The ARNO FAST CHANGE system is 100% through coolant. The innovation starts at the gang plate which acts as a manifold, delivering coolant to the tools behind the scenes. This means you get high pressure coolant directly to the cut zone without adjusting spigots or having to plumb tools individually. How cool is that?



**FAST, ACCURATE, SECURE:**

**THE INNOVATIVE, UNCOMPROMISING SWISS QUICK CHANGE TOOLING SYSTEM**

Get to know ARNO USA

## WE LIVE QUALITY TOOLING

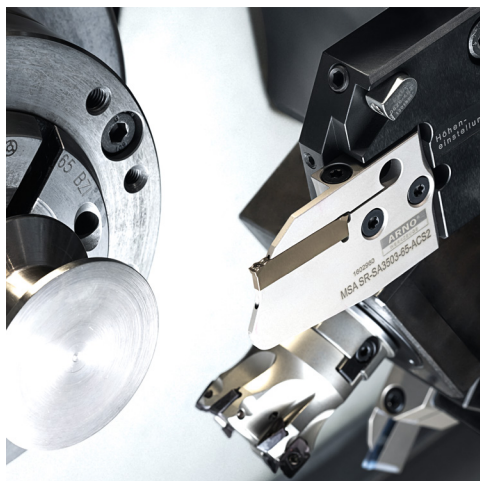

ARNO USA is your solutions provider for high production, precision turned part machining.

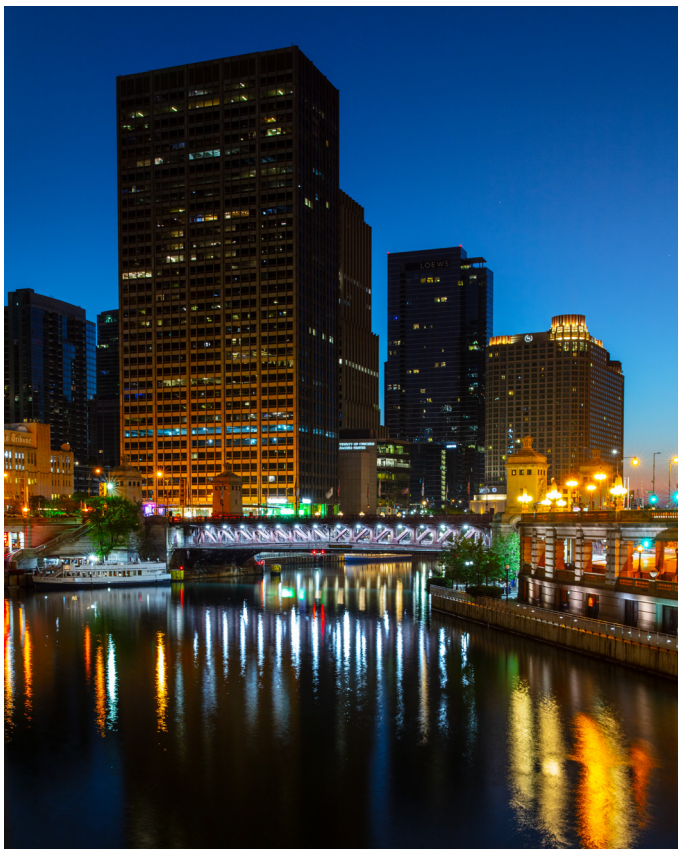

ARNO USA  
1101 W. Diggins Street  
Harvard, IL 60033

Contact us: 815-943-4426  
Request Information: [info@arnousa.com](mailto:info@arnousa.com)  
Learn more: [www.arnousa.com](http://www.arnousa.com)

Or simply scan to access more information



 FAST CHANGE



 YouTube